



Rigel g200

200W High Power, Diode Pumped Short Pulse Laser

A Q-switched, intra-cavity frequency doubled laser, delivering high average powers up to 200 W in an unpolarised multi-mode beam at a wavelength of 532 nm. With a well proven rugged head design, state of the art universal control system architecture, simple synchronisation with OEM equipment and process lines, this platform is ideally suited to high volume industrial applications.

Rigel g200

Rigel g400

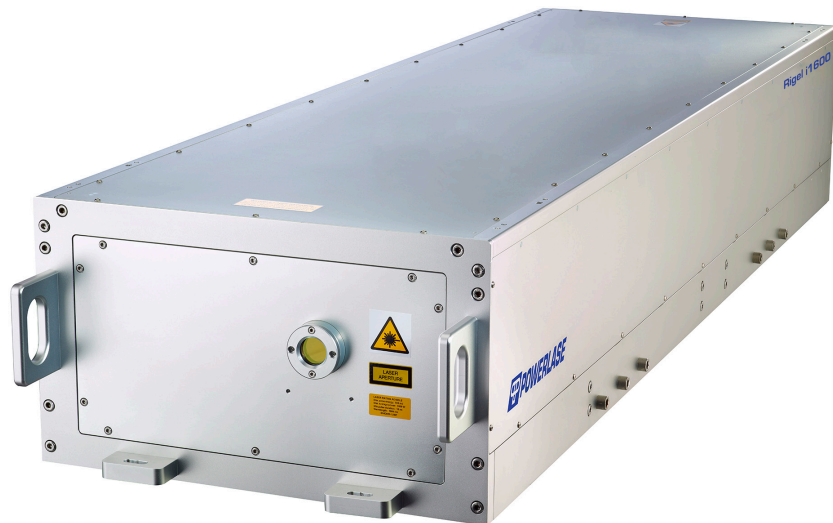

Features

- Pulse Energy Up To 20 mJ
- $M^2 = 28$
- Excellent Stability
- Condition Monitoring
- Optional Fibre Delivery (Round Or Square)
- Computer Controlled Attenuation
- Optional Repetition Frequency Optimisation

Applications

- Photovoltaic Processing
- Poly-Silicon Annealing
- Hard Materials Processing
- Micro Machining
- Ti:Sapphire Pumping

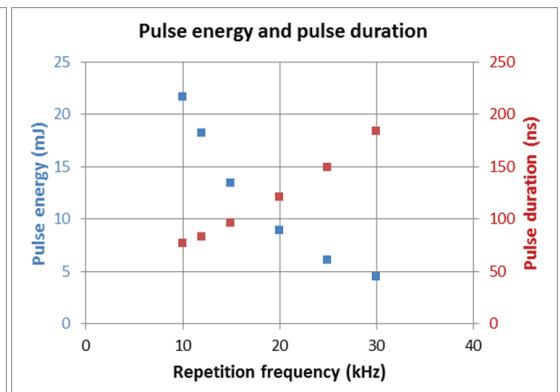
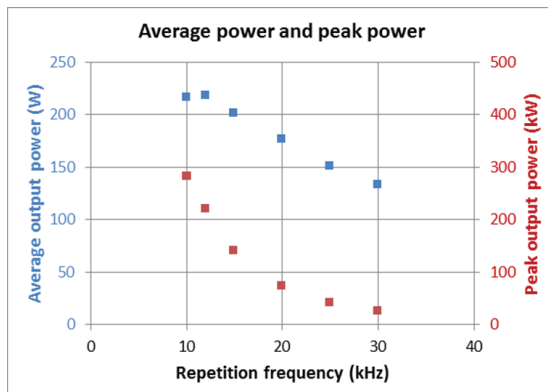



Typical Laser Performance

Pulse Repetition Freq. (kHz)	10	15	20	30
Average Power (W)	210	200	175	130
Pulse Energy (mJ)	21	13	9	4
Pulse Duration (ns)	75	95	120	180
Divergence (mrad, 1/e ² FA)	6			
M ²	28			
Power Stability (% , 1σ)	0.5			
Typical Fibre Core (µm)	400			

Facility Requirements

Rigel g200

Rigel g400

Supply Voltage	3-phase N+E, 220 or 400 VAC (±10%)
Supply Frequency	50 or 60 Hz
Nominal Power Consumption	13 kVA
Cooling Water	20 litres/min at 11 - 17°C
Gas Purge	N ₂ or Air (Grade N5.0, <1 ppm THC)
Laser Dimensions	1600 x 500 x 215 mm
Control Rack Dimensions	1195 x 600 x 970 mm (h w d)
Environmental Conditions	Temp 15 - 32°C and RH <60% (90% max, non condensing)

Specifications subject to change without notice.

Dimensions

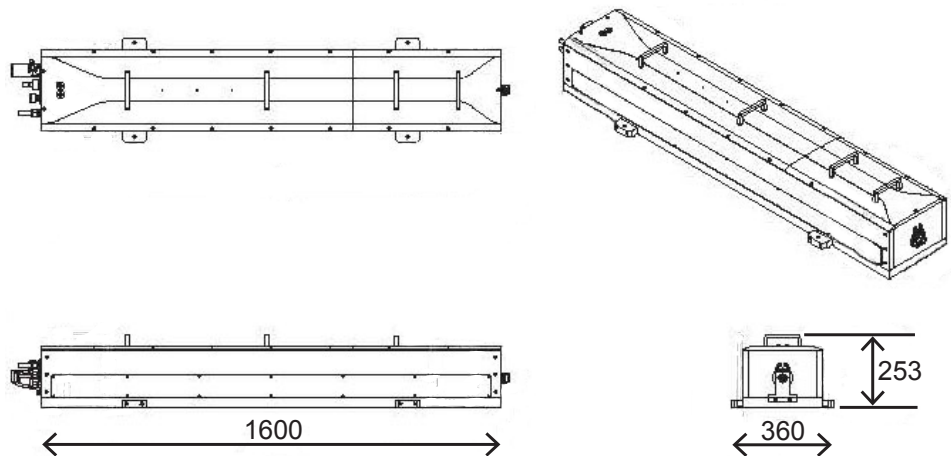

LASER RADIATION
AVOID EYE OR SKIN EXPOSURE TO
DIRECT OR SCATTERED RADIATION
CLASS 4 LASER PRODUCT

ANDRITZ Powerlase may make improvements and/or changes in the products described herein at any time without notice.

Doc No: 069-0042-2

Andritz Powerlase Ltd, Units 3 & 4, Meadowbrook Industrial Estate, Maxwell Way,
Crawley, West Sussex. RH10 9SA United Kingdom.

Tel: +44 (0) 1293 456222 Email: sales@powerlase-photonics.com